

Lug Style Butterfly Valve Type 578



General

- **Size:** 2"–12"
- **Outer Body:** Glass-filled PP
- **Material:** PVC, CPVC, PROGEF® Standard PP, ABS, SYGEF® Standard PVDF
- **Seals:** EPDM, FPM, PTFE/FPM
- **Stem:** 316 Stainless steel
- **Lugs:** 316 Stainless steel
- **Connection:** ANSI 150
- **Operation:** Bare shaft, lever, gear

Key Certifications

- **NSF 61:** PVC and CPVC
- **FDA CFR 21 177.1520:** PP and PVDF
- **FDA CFR 21 177.2600:** EPDM and FPM
- **FDA CFR 21 177.1550:** PTFE
- **USP 25 Class VI (physiological non-toxic):** PP and PVDF

Specification

The Type 578 Butterfly Valve shall be lug style compatible with ANSI B16.5 150 lb flange pattern. The operation shall utilize double eccentric design principles. The shaft shall be non-wetted by a bushing assembly with double o-ring seals. The face seal shall be a Q-ring compatible with flat and serrated flange adapters. The face, disk and shaft seals shall operate independently. The wetted body and disk shall be of like materials. The outer body shall be glass-filled polypropylene with over-molded 316 stainless steel lug inserts. Valves shall be rated for bidirectional use. All valves shall be tested in accordance to ISO9393 and designed to ISO16136 standards. All valves shall be manufactured under ISO9001 for Quality and ISO14001 for Environmental Management. Following assembly, every valve shall be tested and certified bubble tight exceeding Class VI standards.

Material Specification

PVC valves shall meet ASTM D1784 cell classification 12454 standards. CPVC valves shall meet ASTM D1784 cell classification 23447-B standards. PP valves shall meet ASTM D5847-14 cell classification PP0510B66851 standards. ABS valves shall meet ASTM D3965 cell classification 42222 standards. PVDF valves shall be type 1, grade 2 according to ASTM D3222 standards. Valves of all materials shall be RoHS compliant.

Components

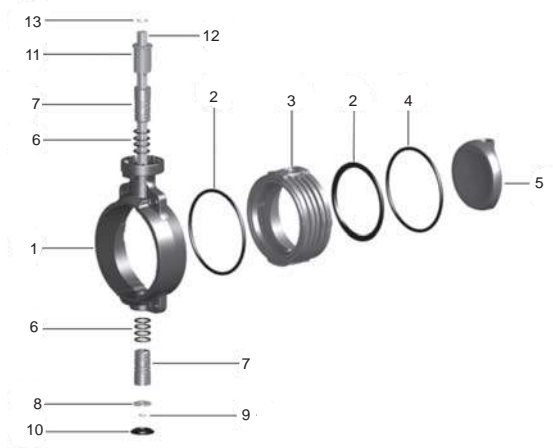

Operator Components

Lever



Gear Operator

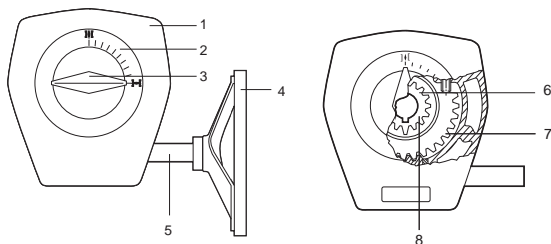

Optional Features

- **Actuation:** Electric, pneumatic
- **Limit Switches:** Mechanical, inductive
- **Handle:** Find adjustment lever (1°), stem extension
- **Shaft:** Titanium, Hastelloy-C
- **Operation:** Chain operator, square operating nut
- **Gear Operator:** Stainless steel housing
- **Connection:** DIN 2501
- **Hardware:** Alternatives available upon request
- **Cleaned:** Silicone free/oil free

Valve Components

Part	Description	Material
1	Outer body	Glass filled PP
2	Face seal	EPDM or FPM
3	Inner body	PVC, CPVC, PP, ABS or PVDF
4	Disk seal	EPDM, FPM or PTFE/FPM
5	Disk	PVC, CPVC, PP, ABS or PVDF
6	Shaft seal	EPDM or FPM
7	Shaft bushing	PVC, CPVC, PP, or PVDF
8	Washer	304 stainless steel
9	Lower retaining clip	304 stainless steel
10	Shaft cap	Glass filled PP
11	End stop	Glass filled PP
12	Shaft	316 stainless steel
13	Upper retaining clip	304 stainless steel

Lever Components

Part	Description	Material
1	Handle clip	Glass-filled PP
2	Handle	Glass-filled PP
3	Spring	304 Stainless steel
4	Lever	Glass-filled PP
5	Bolts	304 Stainless steel
6	Index plate	Glass-filled PP
7	Turn limiter	Glass-filled PP
8	Washers	304 Stainless steel
9	Nuts	304 Stainless steel

Gear Components

Part	Description	Material
1	Housing	Aluminum
2	Indicator cap	PE
3	Indicator	PE
4	Handle	Aluminum
5	Wormshaft	Nitempered steel
6	Drive bushing	Sintered copper steel
7	Quadrant	Sintered copper steel
8	Thrust bearing	Type AXK

Material Availability

Material	Range (inch)	Range (mm)
PVC	2-12	63-315
CPVC	2-12	63-315
PP	2-12	63-315
ABS	2-8	63-225
PVDF	2-12	63-315

Key Design Features

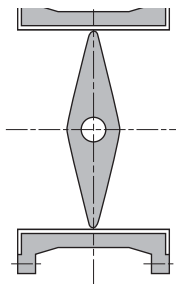

Centric

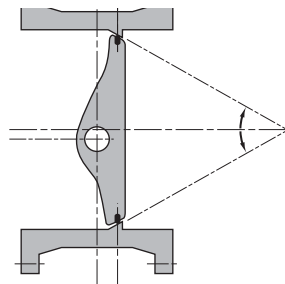

Double Eccentric

Lugs

The Type 578 Butterfly Valve lugs are overmolded SS316. They are keyed and notched to ensure they do not pull-out or rotate when in use.



It is not possible to use inner housings with disks of different material. Valves of all sizes and materials are available with either EPDM, FPM or PTFE/FPM seals. Georg Fischer does not offer disc seals that deviate from their standard product offering.

Double Eccentric Design Principle

The Type 578 Butterfly Valve is designed using the double eccentric disc principle. When opening and closing, the disc is not in contact with the seat, significantly reducing component wear. This design principle greatly reduces the operating torque and required elastomeric sealing material. The reduction in sealing material decreases the impact of elastomeric swelling. The benefits of double eccentric valves include ease of manual usage, reduction in required actuator torque and extended valve lifetime.

Shaft Seal

The Type 578 Butterfly Valve features a truly non-wetted shaft design. The shaft is sealed with a bushing on either side of the disc. Each bushing utilizes a double oring seal totalling eight shaft seals in every valve.



PTFE Disc Seal

The Type 578 Butterfly Valve is available with a PTFE encapsulated FPM disc seal. The FPM core provides flexibility to the PTFE shell and allows for a reliable seal. The double eccentric design limits the amount of PTFE required. The face and shaft seals are FPM blended with 15% PFA.



Technical Data

Pressure-Temperature Curves

The following graphs are based on a lifetime of 25 years of water or similar media applications

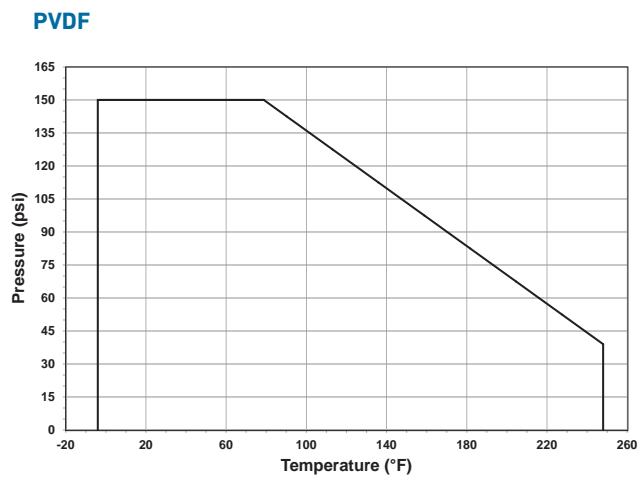
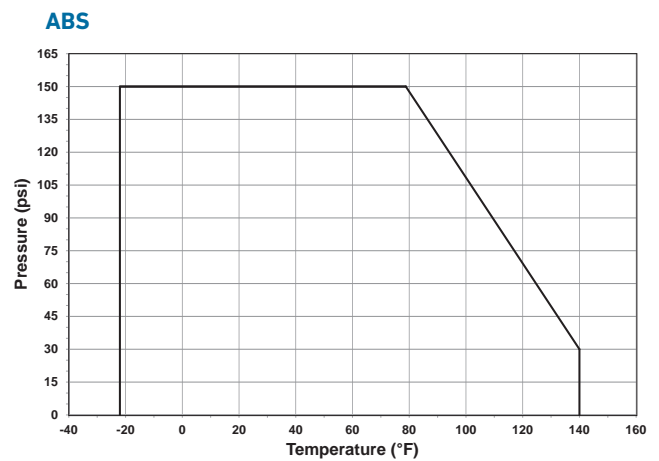
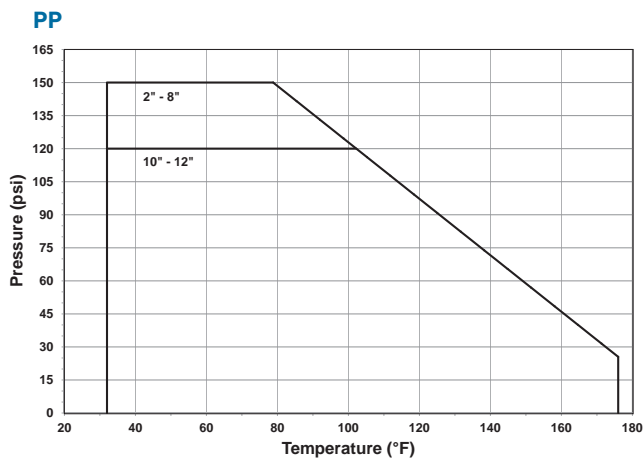
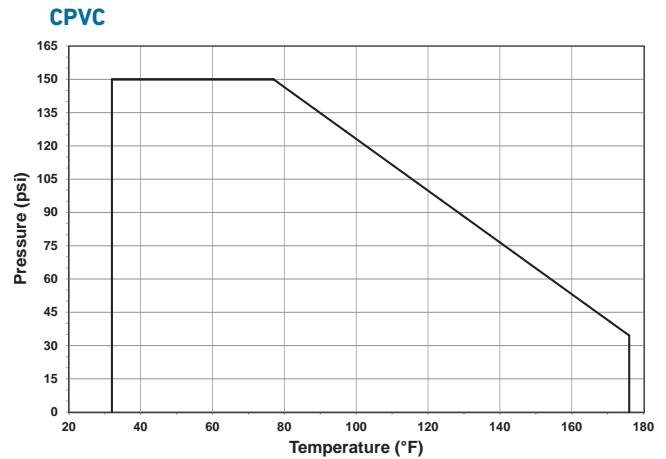
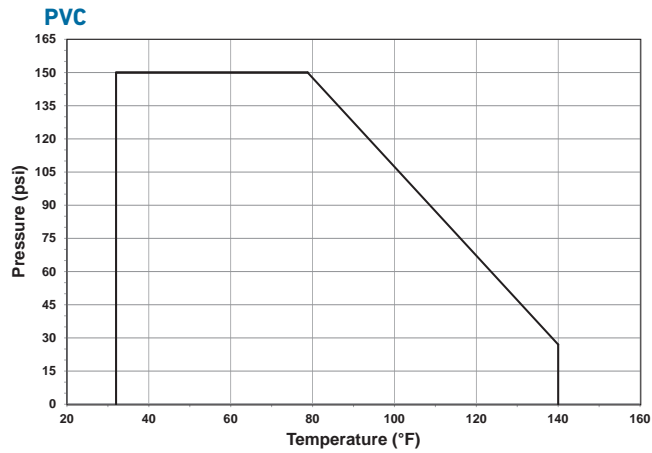

Pressure-Temperature

Material	Temperature Range (°F)	Max Pressure (psi)
PVC	32 to 140	150
CPVC	32 to 176	150
PP	32 to 176	150
ABS	-40 to 140	150
PVDF	-4 to 284	150

The Type 578 is rated for full vacuum service. Maximum differential pressure of 15psi at 122°F.

Flow

The following information is based on water applications at 68° F

Pressure Loss

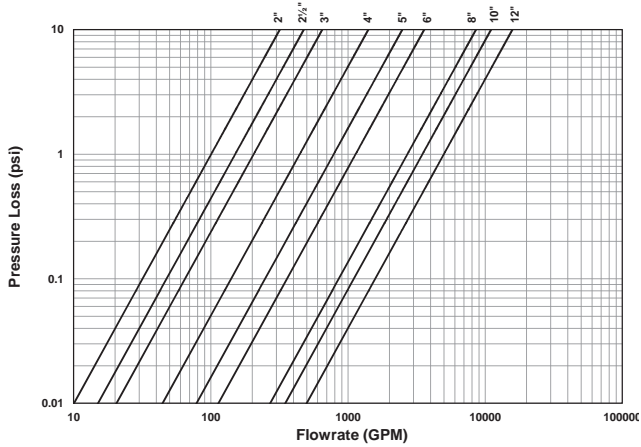

Flow Characteristics

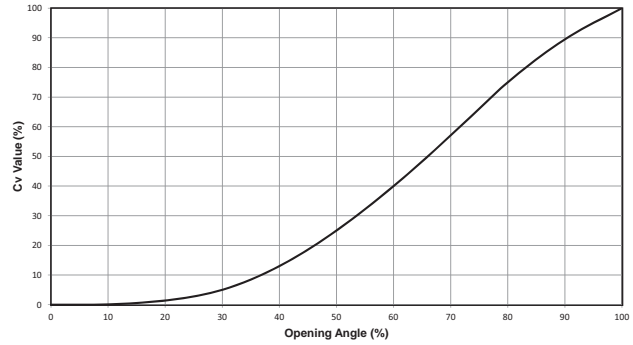

Cv Value

Size (Inch)	d (mm)	Cv (gal/min)
2	63	103
2½	75	154
3	90	210
4	110	455
5	140	805
6	160	1162
8	225	2772
10	280	3570
12	315	5110

Breakaway Torque

The following tables show average values

Size (inch)	d (mm)	At 75psi Torque (ft-lb)	At 150psi Torque (ft-lb)
2	63	10	25
2½	75	10	30
3	90	20	45
4	110	30	60
5	140	40	75
6	160	50	90
8	225	75	120
10	280	100	170
12	315	130	220

For non-GF actuators, a safety factor should be used in calculating the required actuator torque. This safety factor can vary depending on the application conditions and end user's preference. (e.g. control time, medium, temperature, etc.).

Weight

The following table shows unpacked valve weight

Size (inch)	d (mm)	Weight (lb)
2	63	1.5
2½	75	1.8
3	90	2
4	110	3
5	140	4
6	160	5.9
8	225	9.2
10	280	22.7
12	215	242

Valve weights shown are bare shaft and are approximate.
 Gear operator weight is 3 lb.
 Lever weight is 1 lb.

Dimensions

The following tables are shown in inches unless otherwise specified

Bare Shaft

Size	D3	D4	H3	H4	H5 (mm)
2	2.76	3.54	1.06	0.91	11
2½	2.76	3.54	1.06	0.91	11
3	2.76	3.54	1.06	0.91	11
4	2.76	3.54	0.63	0.91	14
5	2.76	3.54	0.63	0.91	14
6	2.76	3.54	0.75	0.91	17
8	2.76	3.54	0.75	0.91	17
10	4.02	4.92	1.57	0.91	22
12	4.02	4.92	1.57	0.91	22

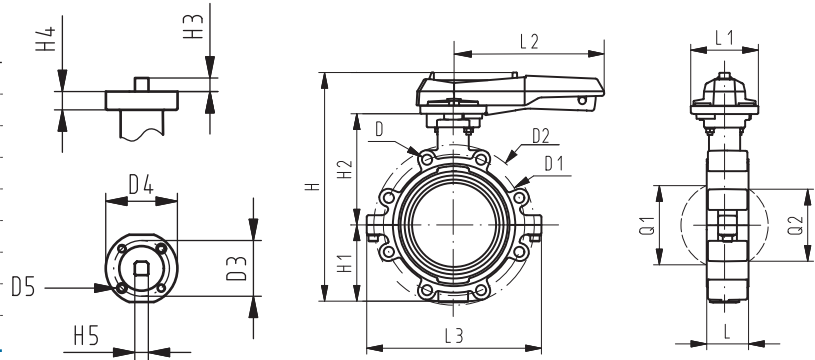

Lever

Size	D	D1	D2	H	H1	H2	L	L1	L2	L3	Q1	Q2
2	UNC 5/8	4.75	6.3	10.43	3.03	5.28	1.77	0.91	8.07	6.5	1.57	-
2½	UNC 5/8	5.5	7.09	10.91	3.27	5.51	1.81	0.91	8.07	7.17	2.13	1.38
3	UNC 5/8	6	7.68	11.38	3.5	5.75	1.93	0.91	8.07	8.27	2.64	1.97
4	UNC 5/8	7.5	8.9	12.91	4.17	6.57	2.2	0.91	10.04	9.45	3.46	2.91
5	UNC 3/4	8.5	10.16	14.06	4.76	7.13	2.52	0.91	10.04	10.71	4.45	3.82
6	UNC 3/4	9.5	11.18	14.84	5.24	7.44	2.83	0.91	10.04	11.81	5.47	4.84
8	UNC 3/4	11.75	13.43	17.17	6.26	8.27	2.87	0.91	16.06	14.17	7.01	6.65
10	UNC 7/8	14.25	16.22	21.1	8.07	10.39	4.45	0.91	16.06	17.32	8.27	8.15
12	UNC 7/8	17	18.98	23.07	9.21	11.22	4.45	0.91	16.06	20.08	10.08	9.96

Gear

Size	D3	H3	L1	L2	L3
2	5.91	1.97	4.33	4.72	6.1
2½	5.91	1.97	4.33	4.72	6.1
3	5.91	1.97	4.33	4.72	6.1
4	5.91	1.97	4.33	4.72	6.1
5	5.91	1.97	4.33	4.72	6.1
6	5.91	1.97	4.33	4.72	6.1
8	5.91	1.97	4.33	4.72	6.1
10	7.87	2.17	5.12	5.51	7.87
12	7.87	2.17	5.12	5.51	7.87

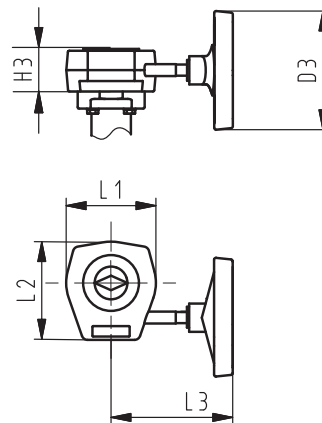

GF Piping Systems

Tel. (714) 731-8800, Toll Free (800) 854-4090, Fax (714) 731-6201
 us.ps@georgfischer.com, www.gfpiping.com

