

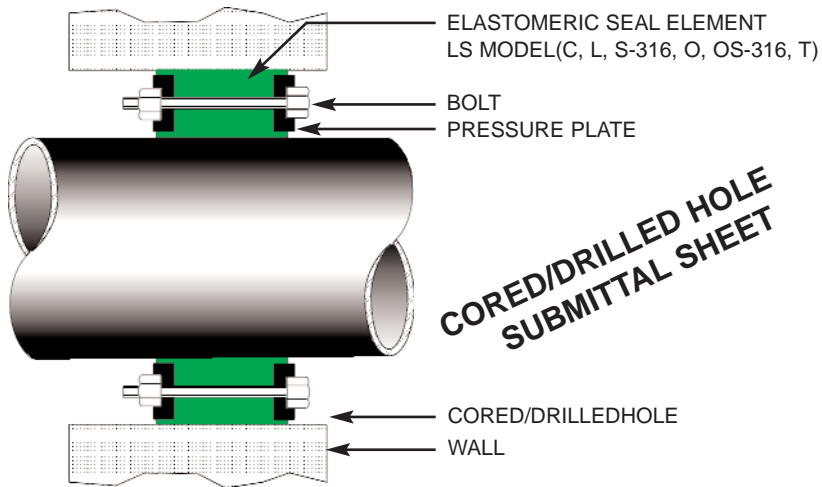

PSI-Thunderline/Link-Seal®

6525 Goforth Street, Houston TX 77021 U.S.A.
 Tel: 713-747-6948, Fax: 713-747-6029
 Toll Free: 800-423-2410, www.linkseal.com

LOCAL LINK-SEAL® MODULAR SEAL REPRESENTATIVE



JOB _____

CUSTOMER _____

P.O. # _____

DATE _____

SUBMITTED BY _____ DATE _____

APPROVED BY _____ DATE _____

LINK-SEAL® MODEL NO. EXAMPLE **LS - 400 - C - 10**

LINK-SEAL® _____

SIZE _____

MODEL _____

NO. OF LINKS _____

QTY.	PIPE SIZE & TYPE	PIPE O.D.	LINK-SEAL® MODEL NO.	CORED/DRILLED HOLE DIAMETER	LOCATION OR TAG NO.

VISIT WWW.LINKSEAL.COM FOR LITERATURE AND INSTALLATION TECHNIQUES



Submittal CH 10-05
 ©2005, Pipeline Seal & Insulator, Inc.